



INSTALLATION INSTRUCTIONS

Accessory
18" ALUMINUM WHEEL
 P/N 08W18-SZA-101

Application
2014 PILOT
 (EX, EX-L, Touring)

Publications No.
All 50234

Issue Date
AUG 2013

PARTS LIST

Aluminum wheel
 (The illustration may differ from the actual wheel.)

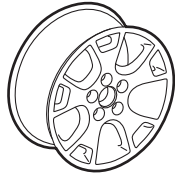

Wheel center cap
 (The illustration may differ from the actual center cap.)

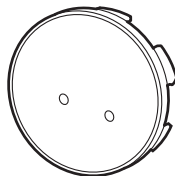

Center cap emblem



2 Push nuts



Tire pressure information label



TPMS Information
 (Give this information to your customer)

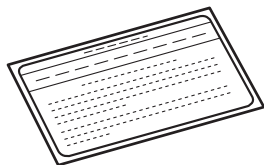

Wheel cleaning information
 (Give this information to your customer)

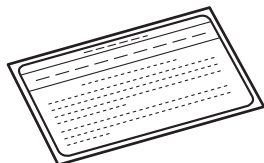

Parts for TPMS sensor assembly

Tire pressure sensor assembly

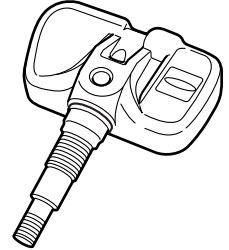

Washer



Valve nut



TOOLS AND SUPPLIES REQUIRED

- Ratchet wrench
- 11 mm Socket
- Torque wrench
- Isopropyl alcohol
- Shop towel
- HDS

SPECIFICATIONS

Models not equipped with standard 18" wheels:

Rim size	18 x 7½ J (offset 45)	
Tire size	245/60R18 104T	
Bolt hole PCD	120 (5 holes)	
Tire pressure	Front	220 kpa (2.3 kgf/cm², 32 psi)
	Rear	220 kpa (2.3 kgf/cm², 32 psi)

Models equipped with standard 18" wheels:

Refer to the owner's manual.

INSTALLATION

Customer Information: The information in this installation instruction is intended for use only by skilled technicians who have the proper tools, equipment, and training to correctly and safely add equipment to your vehicle. These procedures should not be attempted by “do-it-yourselfers.”

NOTE:

- This aluminum wheel is designed for use on vehicles equipped with a TPMS (Tire Pressure Monitoring System).
- This aluminum wheel is equipped with a TPMS sensor. See the service manual for the tire replacement and TPMS sensor installation procedures.
- Install the correct size tire.
- Use a tire changer to install and remove the tires. Do not use a tire lever, as it may cause damage to the tire and aluminum wheel.
- Be careful not to damage the wheel center cap when installing the emblem.
- The center cap emblem should be installed only if the ambient air temperature is 15°C (60°F) or above.
- To allow the adhesive to cure, do not wash the vehicle for 24 hours.

1. Using isopropyl alcohol on a shop towel, clean the area where the center cap emblem will attach.

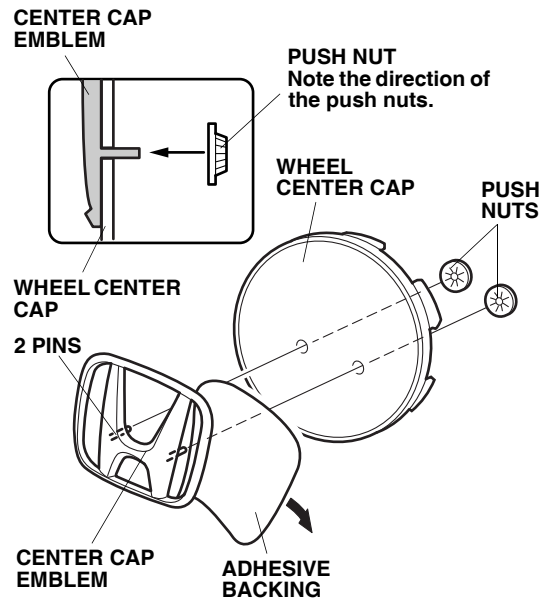

2. Remove the adhesive backing from the center cap emblem.
3. Attach the center cap emblem to the wheel center cap by aligning its pins with the holes in the wheel center cap. After attaching, hold the emblem firmly against the wheel center cap with the palm of your hand for 30 seconds.
4. Slide the two push nuts onto the two pins. Note the direction of the push nuts.

- Before installing the tire pressure sensor, clean the mating surface on the sensor and the aluminum wheel.

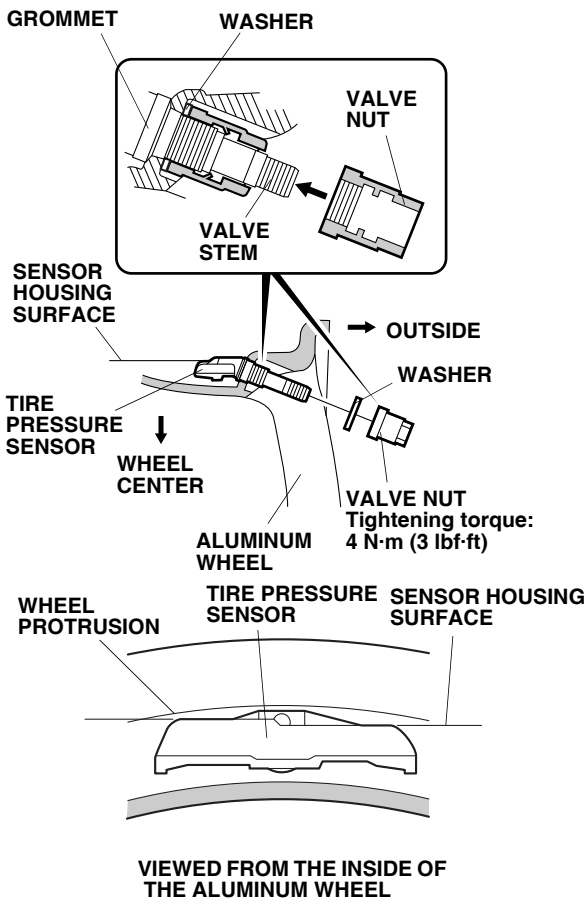

- Install the tire pressure sensor and the washer on the aluminum wheel, and tighten the valve nut finger tight. Make sure the pressure sensor is resting on the wheel.
- Tighten the valve nut to the specified torque while holding the tire pressure sensor toward the wheel. Tightening torque: 4 N·m (3 lbf·ft)

NOTE:

- Install the tire pressure sensor so that the sensor housing surface does not protrude into the bead area of the wheel.
 - Do not reuse grommets that had been tightened to the specified torque. The valve system may leak.
 - Do not use pneumatic or electric tools on the valve nut.
 - Tightening the nut above the specified torque can damage the grommet.
- Install the tires according to the instructions in the service manual.
 - Install the wheels on the vehicle and torque the wheel nuts to 127 N·m (95 lbf·ft).

MEMORIZING THE TIRE PRESSURE SENSOR ID

- Using the HDS, memorize the tire pressure sensor ID according to the instructions in the service manual.

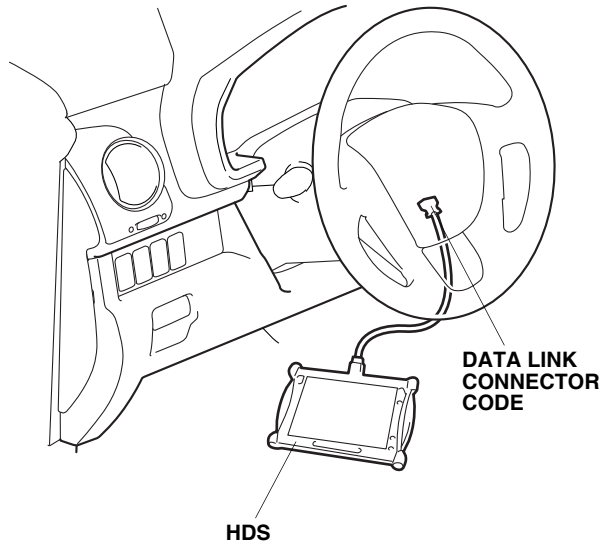

- Open the driver's door. Using isopropyl alcohol, thoroughly clean the area where the new tire pressure information label will attach. Remove the adhesive backing from the label, and apply it over the standard tire information label as shown.

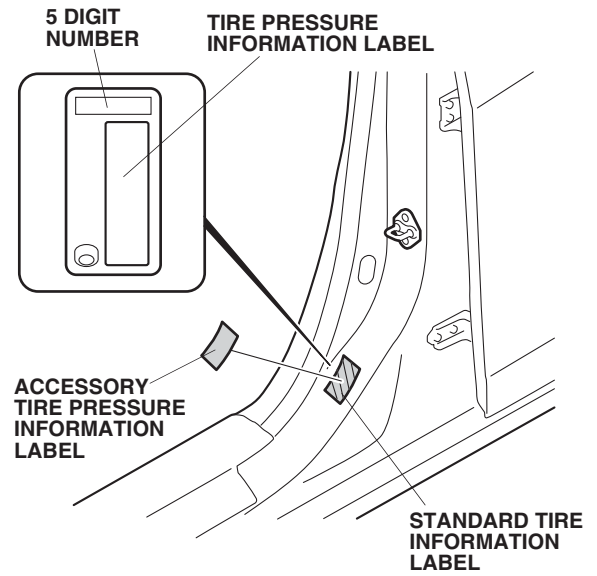

- Insert the Supplemental Information page included in this kit into the owner's manual.